



US 20150188073A1

(19) **United States**

(12) **Patent Application Publication**

AHN et al.

(10) **Pub. No.: US 2015/0188073 A1**

(43) **Pub. Date: Jul. 2, 2015**

(54) **ORGANIC ELECTROLUMINESCENT DEVICE AND ORGANIC ELECTROLUMINESCENT DISPLAY DEVICE**

Publication Classification

(51) **Int. Cl.**
H01L 51/50 (2006.01)
H01L 27/32 (2006.01)
(52) **U.S. Cl.**
CPC *H01L 51/5044* (2013.01); *H01L 27/3209* (2013.01); *H01L 27/3244* (2013.01)

(71) Applicant: **LG DISPLAY CO., LTD.**, Seoul (KR)

(72) Inventors: **So-Yeon AHN**, SEOUL (KR);
Chang-Wook HAN, SEOUL (KR);
Hong-Seok CHOI, SEOUL (KR);
Seung-Ryong JOUNG,
GWANGMYEONG-SI (KR);
Gwi-Jeong CHO, DAEGU (KR);
Hee-Dong CHOI, UIWANG-SI (KR)

(57) **ABSTRACT**

An organic electroluminescent device and organic electroluminescent display device having enhanced efficiency are discussed. In one example, the organic electroluminescent device includes first and second electrodes facing each other on a substrate and at least two emission layers formed between the first and second electrodes and realizing blue light, wherein, among the emission layers, a first blue emission layer close to the first electrode includes a first blue dopant having a different maximum luminescence wavelength than that of a second blue dopant of a second blue emission layer close to the second electrode.

(73) Assignee: **LG DISPLAY CO., LTD.**, SEOUL (KR)

(21) Appl. No.: **14/558,430**

(22) Filed: **Dec. 2, 2014**

(30) **Foreign Application Priority Data**

Dec. 31, 2013 (KR) 10-2013-0168049

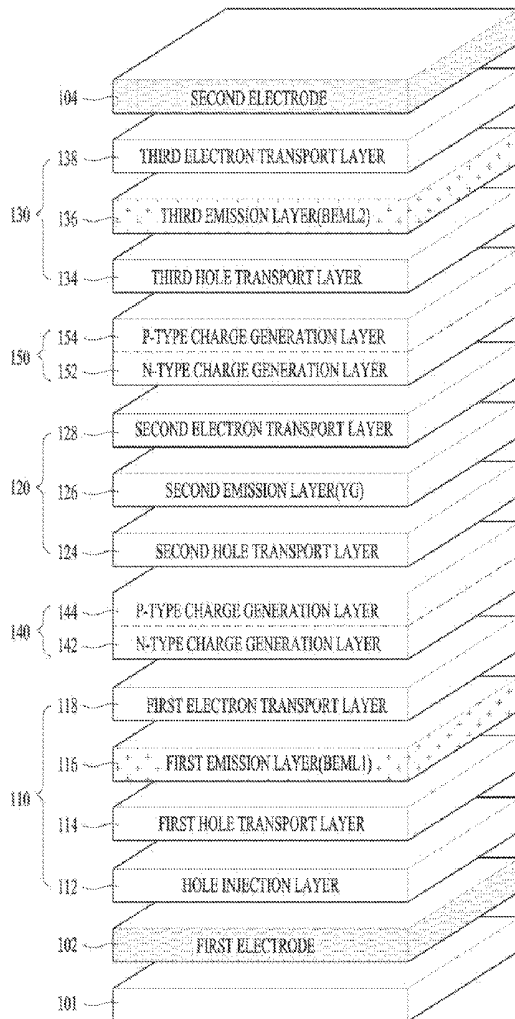

FIG. 1

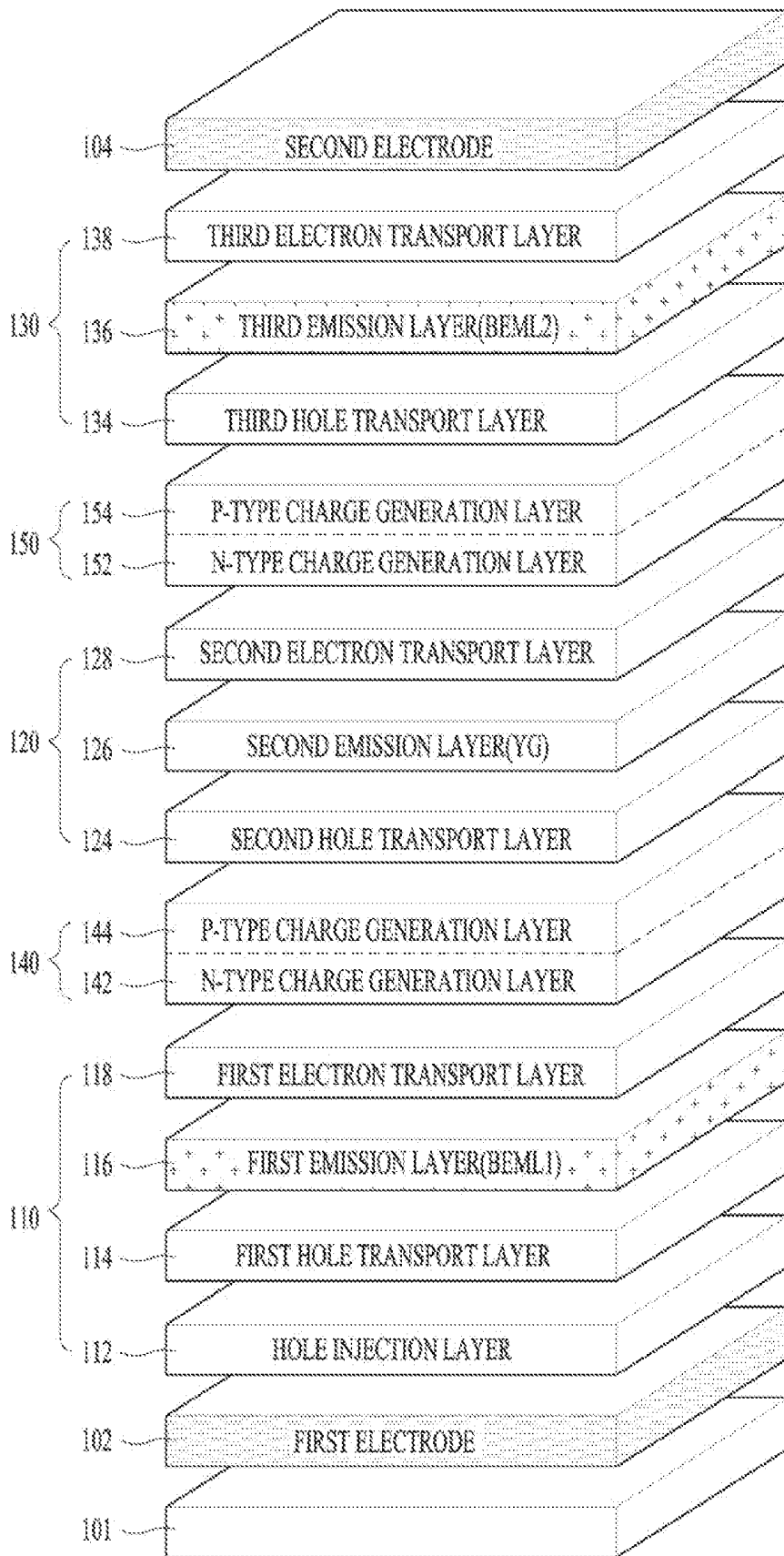

FIG. 2

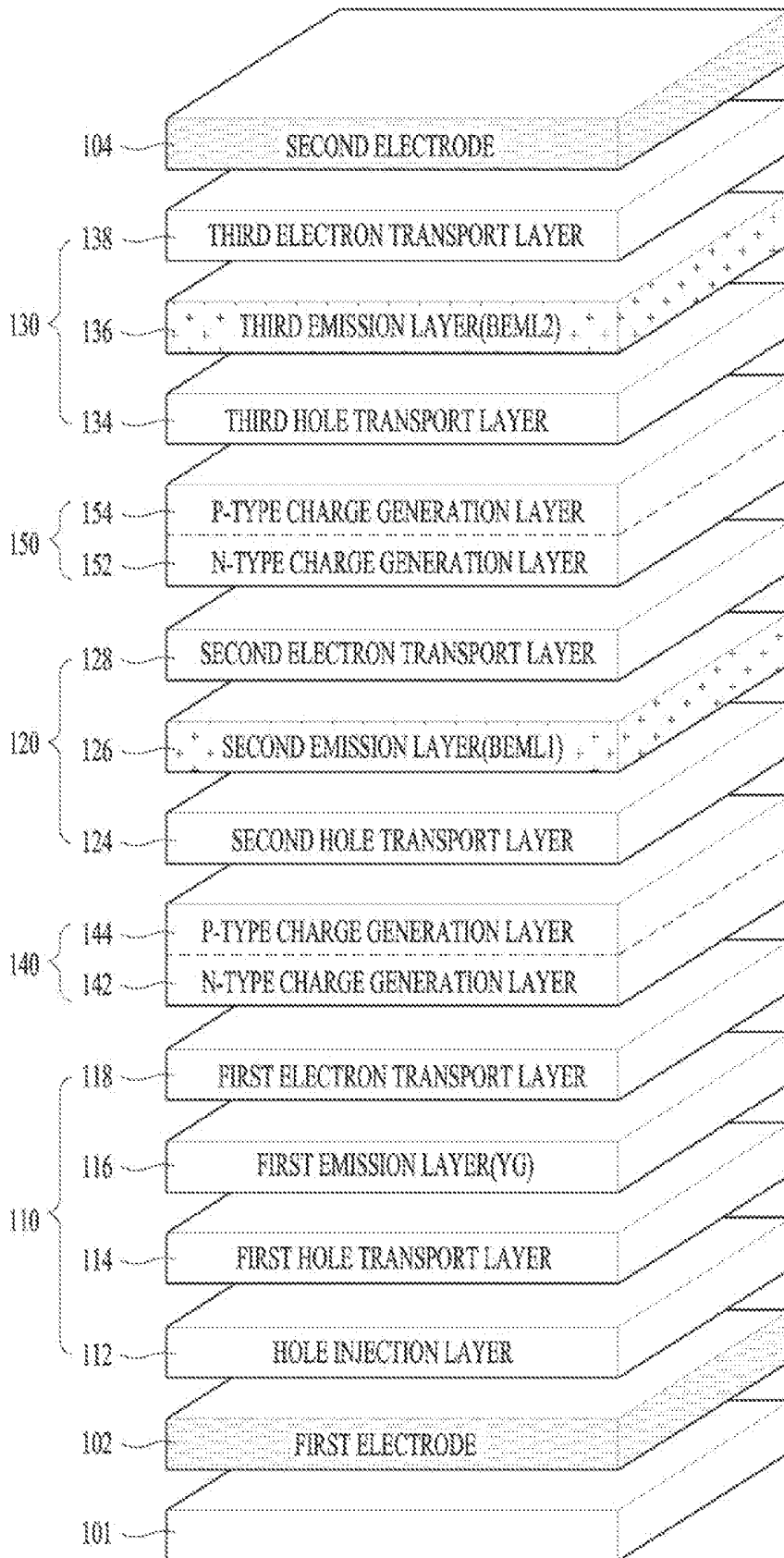

FIG. 3

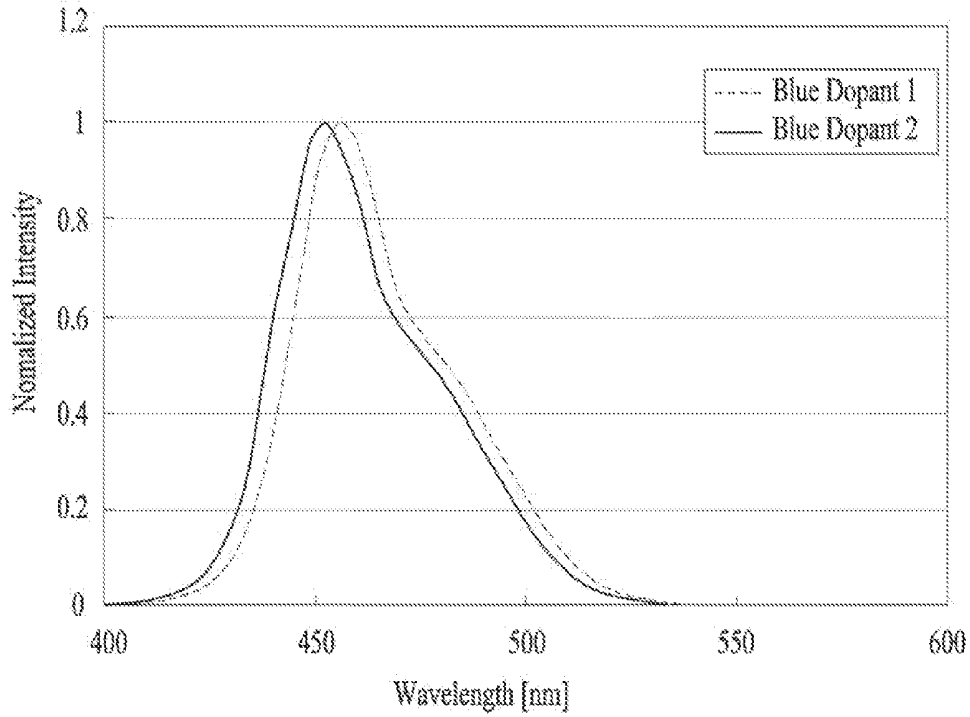

FIG. 4

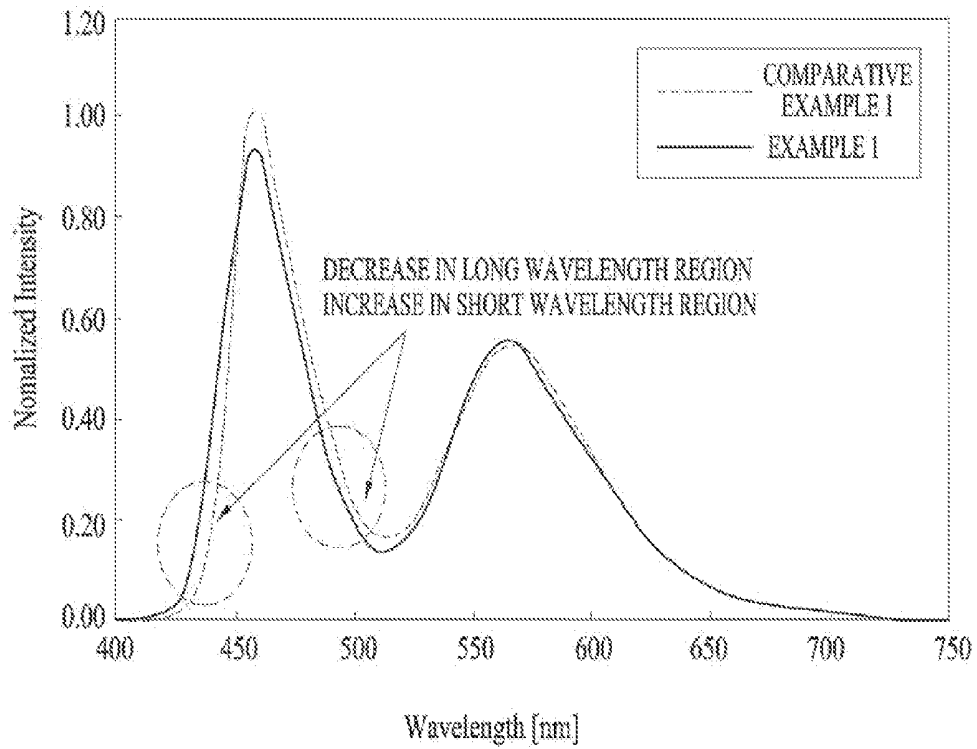

FIG. 5

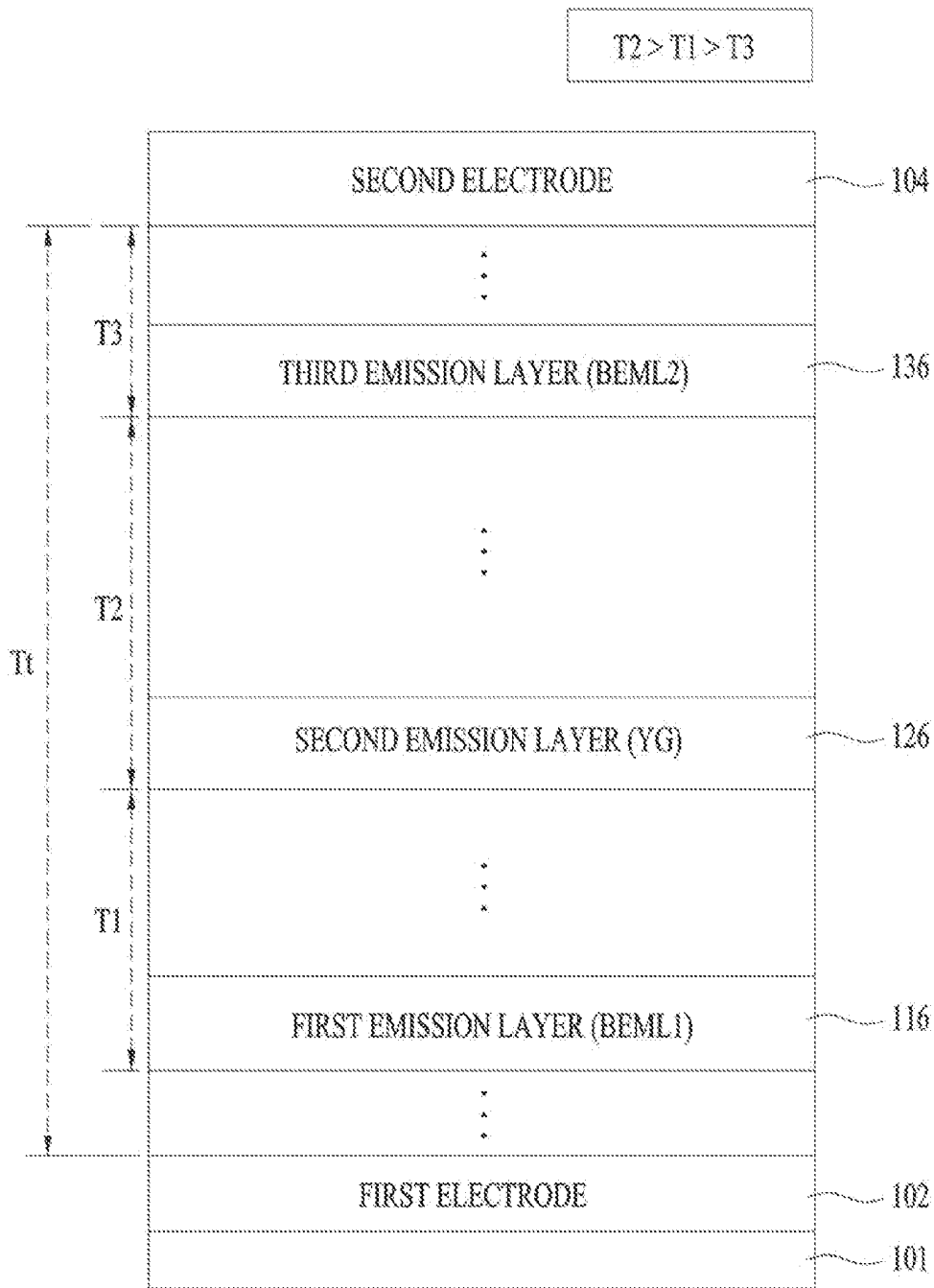

FIG. 6

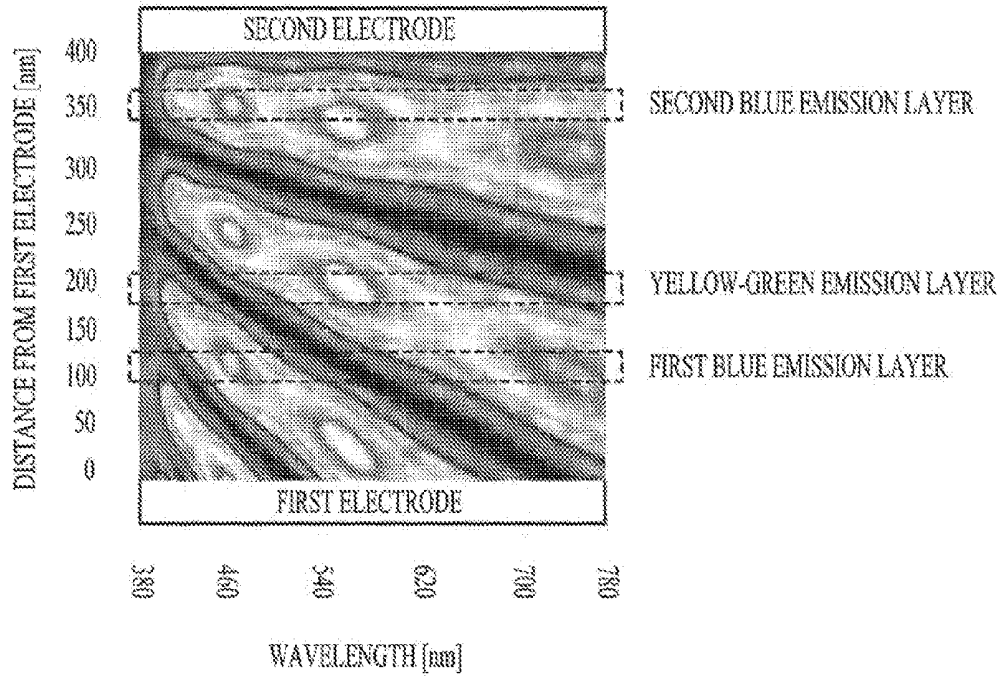

FIG. 7A

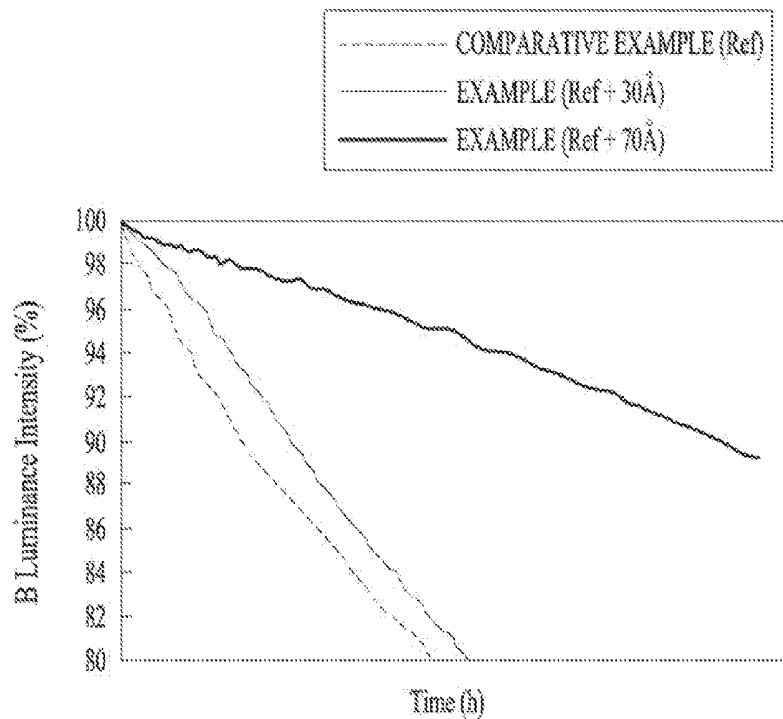
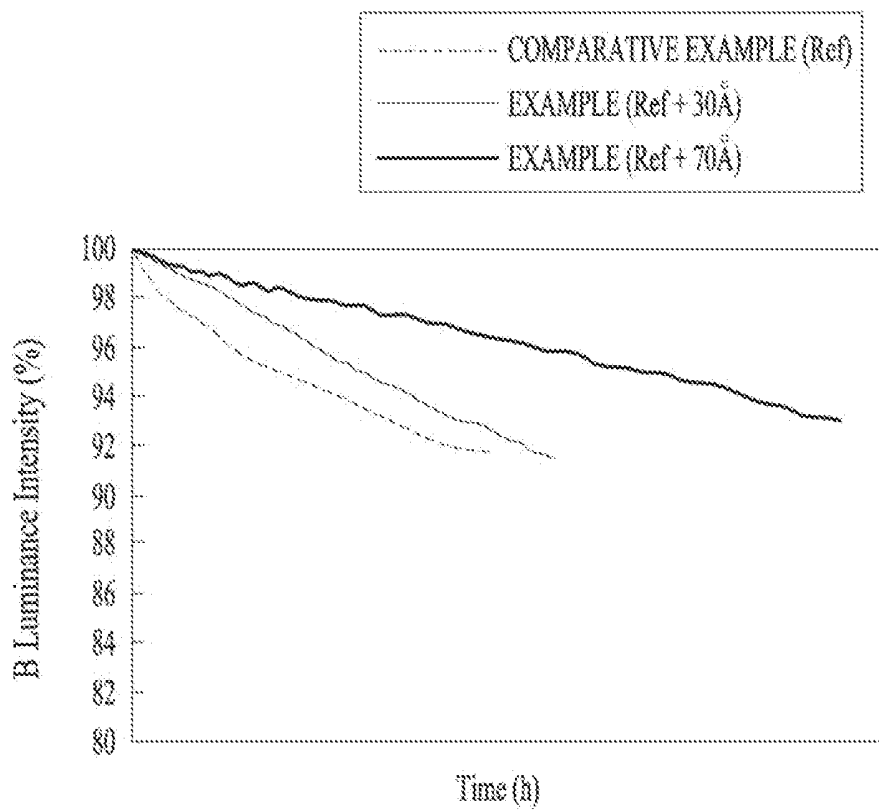

FIG. 7B



**ORGANIC ELECTROLUMINESCENT
DEVICE AND ORGANIC
ELECTROLUMINESCENT DISPLAY DEVICE**

[0001] This application claims the benefit of Korean Patent Application No. 10-2013-0168049, filed on Dec. 31, 2013, which is hereby incorporated by reference as if fully set forth herein.

BACKGROUND OF THE INVENTION

[0002] 1. Field of the Invention

[0003] The present invention relates to an organic electroluminescent device and organic electroluminescent display device having enhanced efficiency.

[0004] 2. Discussion of the Related Art

[0005] With the advent of the information era, the field of displays, which visually display electrical information signals, has rapidly developed. In line with such trend, a variety of ultra-thin and light flat display devices with low power consumption have been developed.

[0006] Examples of such flat display devices include, but are not limited to, a liquid crystal display (LCD) device, a plasma display panel (PDP) device, a field emission display (FED) device, and an organic light emitting device (OLED).

[0007] In particular, OLEDs are self-emissive and have faster response time, higher luminous efficacy, higher brightness and wider viewing angle than other flat display devices. An OLED includes an anode, a hole injection layer, a hole transport layer, an emission layer, an electron transport layer, an electron injection layer, and a cathode.

[0008] Such OLEDs include, between first and second electrodes, a single light emitting unit including a hole injection layer, a hole transport layer, an emission layer, an electron transport layer, and an electron injection layer. However, recently, multiple light emitting units are formed between first and second electrodes.

[0009] However, blue light emitting units included in conventional multiple light emitting units include fluorescent blue emission layers. In this regard, a blue emission layer has a lower efficiency than emission layers that realize other colors and thus total panel efficiency is also reduced.

SUMMARY OF THE INVENTION

[0010] Accordingly, the present invention is directed to an organic electroluminescent device and an organic electroluminescent display device that substantially obviate one or more problems due to limitations and disadvantages of the related art.

[0011] An object of the present invention is to provide an organic electroluminescent device and organic electroluminescent display device having enhanced efficiency.

[0012] Additional advantages, objects, and features of the invention will be set forth in part in the description which follows and in part will become apparent to those having ordinary skill in the art upon examination of the following or may be learned from practice of the invention. The objectives and other advantages of the invention may be realized and attained by the structure particularly pointed out in the written description and claims hereof as well as the appended drawings.

[0013] To achieve these objects and other advantages and in accordance with the purpose of the invention, as embodied and broadly described herein, an organic electroluminescent device includes first and second electrodes facing each other

on a substrate and at least two emission layers formed between the first and second electrodes and realizing blue light, wherein, among the emission layers, a first blue emission layer close to the first electrode includes a first blue dopant having a different maximum luminescence wavelength than that of a second blue dopant of a second blue emission layer close to the second electrode.

[0014] The organic electroluminescent device may further include first, second and third light emitting units formed between the first and second electrodes, wherein any one of the first and second light emitting units includes the first blue emission layer, the other of the first and second light emitting units includes a yellow-green emission layer, and the third light emitting unit includes the second blue emission layer.

[0015] The maximum luminescence wavelength of the first blue dopant may be greater than the maximum luminescence wavelength of the second blue dopant.

[0016] The maximum luminescence wavelength of each of the first and second blue dopants is 430 nm to 480 nm, and the maximum luminescence wavelength of the first blue dopant is greater by 4 nm to 50 nm than the maximum luminescence wavelength of the second blue dopant.

[0017] The maximum luminescence wavelength of the second blue dopant is 430 nm to less than 456 nm, and the maximum luminescence wavelength of the first blue dopant is 456 nm to 480 nm.

[0018] A distance from a rear surface of the first blue emission layer of the first light emitting unit to a rear surface of the yellow-green emission layer of the second light emitting unit may be 600 Å to 1000 Å.

[0019] The organic electroluminescent device may further include N-type and P-type charge generation layers respectively formed between the first and second light emitting unit and between the second and third light emitting units, wherein the N-type charge generation layer disposed between the first blue emission layer of the first light emitting unit and the yellow-green emission layer of the second light emitting unit may have a thickness of 50 Å to 500 Å.

[0020] It is to be understood that both the foregoing general description and the following detailed description of the present invention are exemplary and explanatory and are intended to provide further explanation of the invention as claimed.

BRIEF DESCRIPTION OF THE DRAWINGS

[0021] The accompanying drawings, which are included to provide a further understanding of the invention and are incorporated in and constitute a part of this application, illustrate embodiment(s) of the invention and together with the description serve to explain the principle of the invention. In the drawings:

[0022] FIG. 1 is a perspective view of an organic electroluminescent according to a first embodiment of the present invention;

[0023] FIG. 2 is a perspective view illustrating another example of the organic electroluminescent device according to the first embodiment of the present invention;

[0024] FIG. 3 is a graph showing luminescence wavelengths of first and second blue dopants of first and second blue emission layers illustrated in FIGS. 1 and 2;

[0025] FIG. 4 is a graph showing luminescence characteristics of an organic electroluminescent device according to Comparative Example 1 and the organic electroluminescent device of FIG. 1 (Example 1);

[0026] FIG. 5 is a sectional view of an organic electroluminescent device according to a second embodiment of the present invention;

[0027] FIG. 6 is a contour map of the organic electroluminescent device illustrated in FIG. 5; and

[0028] FIGS. 7A and 7B are graphs showing lifespan characteristics of an organic electroluminescent device according to Comparative Example and the organic electroluminescent device of FIG. 5, according to the thickness of an N-type charge generation layer of a first charge generation layer.

DETAILED DESCRIPTION OF THE INVENTION

[0029] Reference will now be made in detail to the preferred embodiments of the present invention, examples of which are illustrated in the accompanying drawings. Wherever possible, the same reference numbers will be used throughout the drawings to refer to the same or like parts.

[0030] Hereinafter, embodiments of the present invention will be described in detail with reference to the accompanying drawings.

[0031] FIG. 1 is a perspective view of an organic electroluminescent device according to a first embodiment of the present invention.

[0032] The organic electroluminescent device illustrated in FIG. 1 includes first and second electrodes 102 and 104 facing each other on a substrate 101, first, second and third light emitting units 110, 120 and 130 formed between the first and second electrodes 102 and 104, and first and second charge generation layers 140 and 150 respectively formed between the first and second light emitting units 110 and 120 and between the second and third light emitting units 120 and 130.

[0033] At least one of the first and second electrodes 102 and 104 is formed as a semi-transparent electrode. When the first electrode 102 is a semi-transparent electrode and the second electrode 104 is a reflective electrode, the organic electroluminescent device is of a bottom emission type that emits light to the lower side. When the second electrode 104 is a semi-transparent electrode and the first electrode 102 is a reflective electrode, the organic electroluminescent device is of a top emission type that emits light to the upper side. In another embodiment, the first and second electrodes 102 and 104 may be formed as a transparent electrode and thus the organic electroluminescent device is of a dual emission type that emits light to the upper and lower sides.

[0034] The semi-transparent electrode is formed of a transparent conductive material such as indium tin oxide (ITO), indium zinc oxide (IZO), or the like and an opaque conductive material such as aluminum (Al), gold (Au), molybdenum (MO), chromium (Cr), copper (Cu), LiF, or the like. The reflective electrode is formed of a reflective metal material such as Al, Au, Mo, Cr, Cu, LiF, or the like and is formed as multiple layers including such materials.

[0035] In embodiments of the present invention, a case in which the first electrode 102 as an anode is formed as a semi-transparent electrode and the second electrode 104 as a cathode is formed as a reflective electrode will be described by way of example.

[0036] The first light emitting unit 110 is closer to the first electrode 102 than the second and third light emitting units 120 and 130. That is, the first light emitting unit 110 is formed between the first electrode 102 and the first charge generation layer 140. The first light emitting unit 110 includes a hole injection layer 112, a first hole transport layer 114 formed as at least one layer, a first emission layer 116, and a first electron

transport layer 118 that are sequentially formed on the first electrode 102. The first hole transport layer 114 supplies holes from the first electrode 102 to the first emission layer 116, the first electron transport layer 118 supplies electrons from an N-type charge generation layer 142 of the first charge generation layer 140 to the first emission layer 116, and the holes supplied via the first hole transport layer 114 and the electrons supplied via the first electron transport layer 118 are recombined in the first emission layer 116, thereby emitting light.

[0037] The second light emitting unit 120 is formed between the first and third light emitting units 110 and 130. The second light emitting unit 120 includes a second hole transport layer 124 formed as at least one layer, a second emission layer 126, and a second electron transport layer 128 that are sequentially formed on the first charge generation layer 140. The second hole transport layer 114 supplies holes from a P-type charge generation layer 144 of the first charge generation layer 140 to the second emission layer 126, the second electron transport layer 128 supplies electrons from an N-type charge generation layer 152 of the second charge generation layer 150 to the first emission layer 126, and the holes supplied via the P-type charge generation layer 144 of the first charge generation layer 140 and the electrons supplied via the N-type charge generation layer 152 of the second charge generation layer 150 are recombined in the second emission layer 126, thereby emitting light.

[0038] The third light emitting unit 130 is closer to the second electrode 104 than the first and second light emitting units 110 and 120. That is, the third light emitting unit 130 is formed between the second electrode 104 and the second charge generation layer 150. The third light emitting unit 130 includes a third hole transport layer 134, a third emission layer 136, and a third electron transport layer 138 that are sequentially formed on the second charge generation layer 150. The third hole transport layer 134 supplies holes from the P-type charge generation layer 154 of the second charge generation layer 150 to the third emission layer 136, the third electron transport layer 138 supplies electrons from the second electrode 104 to the third emission layer 136, and the holes supplied via the third hole transport layer 134 and the electrons supplied via the third electron transport layer 138 are recombined in the third emission layer 136, thereby emitting light.

[0039] The first charge generation layer 140 includes the N-type charge generation layer 142 and the P-type charge generation layer 144 that are sequentially stacked, and the second charge generation layer 150 includes the N-type charge generation layer 152 and the P-type charge generation layer 154 that are sequentially stacked.

[0040] The P-type charge generation layers 144 and 154 are respectively formed between the second hole transport layer 124 and the N-type charge generation layer 142 and between the third hole transport layer 134 and the N-type charge generation layer 152, thus generating holes and electrons. The holes generated from the P-type charge generation layers 144 and 154 are injected into the second and third hole transport layers 124 and 134 respectively adjacent thereto, and the electrons generated from the P-type charge generation layers 144 and 154 are injected into the N-type charge generation layers 142 and 152.

[0041] The N-type charge generation layers 142 and 152 are respectively formed between the first electron transport layer 118 and the P-type charge generation layer 144 and

between the second electron transport layer **128** and the P-type charge generation layer **154** and inject and transfer the electrons injected from the P-type charge generation layers **144** and **154** into and to the first and second electron transport layers **118** and **128**.

[0042] Meanwhile, the organic electroluminescent device according to the present invention realizes white light using blue light emitted from two (BEML1 and BEML2) of the first, second and third emission layers **116**, **126** and **136** and yellow-green light emitted from the other thereof. That is, as illustrated in FIG. 1, the first emission layer **116** of the first light emitting unit **110** and the third emission layer **136** of the third light emitting unit **130** includes a fluorescent or phosphorescent blue dopant and host and thus emit blue light, and the second emission layer **126** of the second light emitting unit **120** includes a fluorescent or phosphorescent yellow-green dopant and host and thus emits yellow-green light. In another embodiment, as illustrated in FIG. 2, the second and third emission layers **126** and **136** of the respective second and third light emitting units **120** and **130** include a fluorescent or phosphorescent blue dopant and host and thus emit blue light, and the first emission layer **116** of the first light emitting unit **110** includes a fluorescent or phosphorescent yellow-green dopant and host and thus emits yellow-green light.

[0043] In this regard, a first blue emission layer BEML1, which is the first or second emission layer **116** or **126** close to the first electrode **102** illustrated in FIGS. 1 and 2, and a second blue emission layer BEML2, which is the third emission layer **136** close to the second electrode **104** illustrated in FIGS. 1 and 2, have a dopant having a wavelength of 430 nm to 480 nm and may be formed of at least one of materials shown in Table 1 below, but embodiments of the present invention are not limited thereto.

TABLE 1

	Chemical name	PL[nm]
BCzVBi	4,4'-bis(9-ethyl-3-carbazovinyleno)-1,1'-biphenyl	438, 459
Perylene	Perylene	447, 471
TBPe	2,5,8,11-tetra-tert-butylperylene	459
BCzVB	1,4-bis[2-(3-N-ethylcarbazoryl)vinyll]benzene	438, 459
DPAVB	4-(di-p-tolylamino)-4'-[(di-p-tolylamino)styryl]stilbene	476
FIRPic	Bis(3,5-difluoro-2-(2-pyridyl)phenyl-(2-carboxypyridyl)iridium(III)	472
BDAVBi	4,4'-bis[4-(diphenylamino)styryl]biphenyl	461
BNP3FL	N,N'-bis(naphthalen-2-yl)-N,N'-bis(phenyl)-tris-(9,9dimethylfluorenylene)	437
MDP3FL	2,7-bis[2-[phenyl(m-tolyl)amino]-9,9-dimethyl-fluorene-7-yl]-9,9-dimethyl-fluorene	460
N-BDAVBi	N-(4-((E)-2-(6-((E)-4-(diphenylamino)styryl)naphthalen-2-yl)vinyl)phenyl)-N-phenylbenzenamine	469
Spiro-BDAVBi	2,7-bis[4-(diphenylamino)styryl]-9,9-spirofluorene	480
DBzA	6-methyl-2-(4-(9-(4-(6-methylbenzo[d]thiazol-2-yl)phenyl)anthracen-10-yl)phenyl)benzo[d]thiazole	448
DSA-Ph	(E)-6-(4-(diphenylamino)styryl)-N,N-diphenyl-naphthalen-2-amine	469

TABLE 1-continued

	Chemical name	PL[nm]
FIRN4	Bis(2,4-difluorophenylpyridinato)(5-(pyridin-2-yl)-1Htetrazolate)iridium(III)	459
MQAB	(Z)-6-mesityl-N-(6-mesitylquinolin-2(1H)-ylidene)quinolin-2-amine-BF2 complex	451.5, 476
DPAFVF	9-[4-(2-(7-(N,N-diphenylamino)-9,9-diethylfluoren-2-yl)vinyll]phenyl]-9-phenyl-fluorene	465
(pmi)2Ir(ppyz)	Bis(1-phenyl-3-methylimidazol-2-ylidene-C,C2')(2-(2H-pyrazol-3-yl)-pyridine)Iridium(III)	468
(mpmi)2Ir(ppyz)	Bis(1-(4-methylphenyl)-3-methylimidazol-2-ylidene-C,C2')(2-(2H-pyrazol-3-yl)-pyridine)Iridium(III)	471
(fpmi)2Ir(ppyz)	Bis(1-(4-fluorophenyl)-3-methylimidazol-2-ylidene-C,C2')(2-(2H-pyrazol-3-yl)-pyridine)Iridium(III)	468
(fpmi)2Ir(pyim)	Bis(1-(4-fluorophenyl)-3-methylimidazol-2-ylidene-C,C2')(2-(1H-imidazol-2-yl)pyridine)Iridium(III)	474
(fpmi)2Ir(tfppyz)	Bis(1-(4-fluorophenyl)-3-methylimidazol-2-ylidene-C,C2')(2-(5-trifluoromethyl-2H-pyrazol-3-yl)-pyridine)Iridium(III)	456
fac-Ir(dpbc)3	fac-Tris(1,3-diphenyl-benzimidazol-2-ylidene-C,C2')Iridium(III)	472
(fpmi)2Ir(dmpypz)	Bis(1-(4-fluorophenyl)-3-methylimidazol-2-ylidene-C,C2')(3,5-dimethyl-2-(1H-pyrazol-5-yl)pyridine)Iridium(III)	459
(mpmi)2Ir(dmpypz)	Bis(1-(4-methylphenyl)-3-methylimidazol-2-ylidene-C,C2')(3,5-dimethyl-2-(1H-pyrazol-5-yl)pyridine)Iridium(III)	467
PCAN	9-(9-phenylcarbazole-3-yl)-10-(naphthalene-1-yl)anthracene	
PCVtPh	(3-(2-(1,1':4'1''terphen-4-yl)vinyll)-9-phenyl-9H-carbazole	
N-BDAVBi-C6	4,4'-(1E,1'E)-2,2'-(naphthalen-2,6-diyl)bis(ethene-2,1-diyl)bis(N,N-bis(4-hexylphenyl)aniline)	469
FCNIRPic	Bis(3,5-difluoro-4-cyano-2-(2-pyridyl)phenyl-(2-carboxypyridyl) Iridium(III)	460
CC2TA	2,4-Bis{3-(9H-carbazol-9-yl)-9H-carbazol-9-yl}-6-phenyl-1,3,5-triazine	435
FK306	C33H33F4IrN2O2	454
2CzPN	4,5-di(9H-carbazol-9-yl)phthalonitrile	475

[0044] In particular, a first blue dopant included in the first blue emission layer BEML1 is formed of a different material than a second blue dopant included in the second blue emission layer BEML2. In this regard, as illustrated in FIG. 3, the first blue dopant has a greater maximum luminescence wavelength than the second blue dopant. The maximum luminescence wavelength of the first blue dopant is greater by 4 nm to 50 nm than the maximum luminescence wavelength of the second blue dopant.

[0045] FIG. 4 and Table 2 show electro-optical characteristics of organic electroluminescent devices of Example 1 and Comparative Example 1. In FIG. 4 and Table 2, Comparative Example 1 is a case in which first and second blue dopants are formed of the same material, and Example 1 is a case in which the first and second blue dopants are formed of different

materials and thus the maximum luminescence wavelength of the first blue dopant is greater than that of the second blue dopant.

TABLE 2

	Blue color coordinates				EQE (%)	Color gamut (%)
	CIE 1931(x, y)		CIE 1976(u', v')			
Comparative Example 1	0.138	0.055	0.163	0.147	100%	100%
Example 1	0.1417	0.050	0.171	0.135	101%	103%

[0046] As illustrated in FIG. 4, in the case of Example 1, a long wavelength region decreases and a short wavelength region increases when compared to Comparative Example 1 and thus luminescence wavelength peak is sharper than in Comparative Example 1. Accordingly, as shown in Table 2, color coordinates decrease and thus blue color purity and color gamut are enhanced. Thus, in the organic electroluminescent device of Example 1, transmittance of a color filter upon which white light is incident increases as color purity increases and thus efficiency of blue light is enhanced.

[0047] FIG. 5 is a sectional view of an organic electroluminescent device according to a second embodiment of the present invention.

[0048] The organic electroluminescent device of FIG. 5 includes the same elements as those of the organic electroluminescent device of FIG. 1, except that emission layers are formed at specific positions. Thus, a detailed description of the same elements will be omitted herein.

[0049] The emission layers 116, 126 and 136 of the organic electroluminescent device according to the second embodiment of the present invention are arranged as illustrated in FIG. 5.

[0050] A separation distance T1 between the first blue emission layer BEML1, which is the first emission layer 116 close to the first electrode 102, and the second emission layer 126 that realizes yellow-green is less than a separation distance T2 between the second blue emission layer BEML2, which is the third emission layer 136 close to the second electrode 104, and the second emission layer 126 that realizes yellow-green. For example, the separation distance T1, which is a distance from a rear surface of the first emission layer 116 to a rear surface of the second emission layer 126, is 600 Å to 1000 Å, the separation distance T2, which is a distance from the rear surface of the second emission layer 126 to a rear surface of the second blue emission layer BEML2, is 1600 Å to 2000 Å, and a distance T3 from the rear surface of the second blue emission layer BEML2 to the second electrode 104 is 150 Å to 700 Å. Accordingly, a distance Tt from a front surface of the first electrode 102 to a rear surface of the second electrode 104 is 2500 Å to 5600 Å.

[0051] In this case, as illustrated in FIG. 6, a region separated from the first electrode 102 by 2000 Å is a region in which a center of a contour line is located and exhibits the greatest constructive interference of yellow-green light having a maximum luminescence wavelength of 550 nm to 560 nm. Regions separated from the first electrode 102 by about 1000 Å and 3500 Å are regions in which the center of the contour line is located and exhibit the greatest constructive interference of blue light having a maximum luminescence wavelength of 430 nm to 480 nm.

[0052] As such, to exhibit great constructive interference of blue light and yellow-green light, the first blue emission layer BEML1, the first electron transport layer 118, the N and P-type charge generation layers 142 and 144 of the first charge generation layer 140, and the second hole transport layer 124, disposed between the first hole transport layer 114 and the second emission layer 126 that realizes yellow-green, have to be formed to a thickness of 600 Å to 1000 Å. That is, the first thickness T1 from the rear surface of the first blue emission layer BEML1 to the rear surface of the second emission layer 126 that realizes yellow-green has to be 600 Å to 1000 Å. In addition, the thickness of the N-type charge generation layer 142 of the first charge generation layer 140 disposed between the first blue emission layer BEML1 and the second emission layer 126 has to be 50 Å to 500 Å.

[0053] Accordingly, as shown in Table 3 below, it can be confirmed that the organic electroluminescent device of Example having a first thickness T1 of 600 Å or more exhibits enhanced Y color coordinates of blue light and enhanced color gamut, when compared to a conventional organic electroluminescent device in which a first thickness from a rear surface of the first blue emission layer to a rear surface of a second emission layer that realizes yellow-green is less than 600 Å. In addition, it can be confirmed that, as the first thickness T1 increases, enhancement effects of Y color coordinates of blue light and color gamut are increased.

TABLE 3

	Comparative Example 1	Example Thickness of T1		
		Ref(<600 Å)	Ref + 50 Å	Ref + 100 Å
Color coordinates (Y)	0.060	0.058	0.056	0.055
Color gamut	100%	101%	101%	102%

[0054] In addition, when the thickness of the N-type charge generation layer 142 of the first charge generation layer 140 increases within a range within which the distance between the rear surface of the first blue emission layer BEML1 and the rear surface of the second emission layer 126 that realizes yellow-green is 600 Å to 1000 Å, as illustrated in FIGS. 7A and 7B and Table 4 below, it can be confirmed that lifespan of a blue light emitting device and lifespan of a white light emitting display panel including the blue light emitting device are enhanced. In this regard, an N-type charge generation layer of a first charge generation layer of Comparative Example 1 has a thickness Ref of less than 50 Å, while the N-type charge generation layer 142 of the first charge generation layer 140 of Example 1 has a thickness of 50 Å to 500 Å.

TABLE 4

Thickness of N-CGL	Comparative Example	Example		
		Ref(<50 Å)	Ref + 30 Å	Ref + 70 Å
T95(hr)	B	511	916	2723
	W	1862	2869	5486
$\Delta V@T95$		<0.60	<0.40	<0.10

[0055] Tables 5 and 6 show color gamut according to wavelength and efficiency characteristics of blue dopants according to comparative examples and examples.

in efficiency (Cd/A) of blue light and enhanced color coordinates (y) and color gamut as compared to the organic electroluminescent devices of Comparative Examples 6 to 8.

TABLE 5

	Comparative Example 2	Comparative Example 3	Comparative Example 4		Example 2		Comparative Example 5	
Thickness T1	Ref (<600 Å)		Ref + 50 Å					
Second blue dopant	Long wavelength	Long wavelength	Long wavelength	Short wavelength	Short wavelength	Short wavelength	Short wavelength	Short wavelength
First blue dopant	Long wavelength	Long wavelength	Short wavelength	Long wavelength	Long wavelength	Short wavelength	Short wavelength	Short wavelength
Efficiency of blue light (Cd/A)	4.00	4.27	3.67	3.65	3.71	3.91	3.44	3.36
Color coordinates (Y)	0.060	0.066	0.057	0.059	0.052	0.055	0.047	0.052
Color gamut (NTSC1976)	100%	98%	102%	101%	103%	102%	105%	103%

[0056] As shown in Table 5, the organic electroluminescent device of Example 2, in which the first thickness T1 from the rear surface of the first blue emission layer BEM1 to the rear surface of the second emission layer 126 that realizes yellow-green is increased by about 50 Å as compared to organic electroluminescent devices according to Comparative Examples 2 to 5 and the second blue dopant has a shorter wavelength than the first blue dopant, exhibits little reduction in efficiency (Cd/A) of blue light and enhanced color coordinates (y) and color gamut as compared to the organic electroluminescent devices of Comparative Examples 2 to 5. Accordingly, in the organic electroluminescent device of Example 2, the thickness of the N-type charge generation layer 142 of the first charge generation layer 140 may be increased due to a margin for the first thickness T1 and thus lifespan thereof is enhanced as compared to the organic electroluminescent devices of Comparative Examples 2 to 5.

Accordingly, in the organic electroluminescent device of Example 3, the thickness of the N-type charge generation layer 142 of the first charge generation layer 140 may be increased due to a margin for the first thickness T1 and thus lifespan thereof is enhanced as compared to the organic electroluminescent devices of Comparative Examples 6 to 8.

[0058] Meanwhile, in the present invention, although a case in which three light emitting units are formed has been described by way of example, four or more light emitting units including two blue emission layers may be formed.

[0059] As is apparent from the foregoing description, organic electroluminescent devices according to one or more embodiments of the present invention include at least two blue emission layers with different maximum luminescence wavelengths. In particular, a blue emission layer close to a second electrode as a cathode has a blue dopant having a shorter wavelength than that of a blue emission layer close to a first electrode as an anode. Accordingly, the organic electroluminescent devices may have enhanced efficiency, lifespan and color purity.

[0060] It will be apparent to those skilled in the art that various modifications and variations can be made in the present invention without departing from the spirit or scope of the inventions. Thus, it is intended that the present invention covers the modifications and variations of this invention provided they come within the scope of the appended claims and their equivalents.

What is claimed is:

1. An organic electroluminescent device comprising: first and second electrodes facing each other on a substrate; and

at least two emission layers formed between the first and second electrodes and realizing blue light, wherein, among the emission layers, a first blue emission layer close to the first electrode comprises a first blue dopant having a different maximum luminescence wavelength than that of a second blue dopant of a second blue emission layer close to the second electrode.

2. The organic electroluminescent device according to claim 1, further comprising:

first, second and third light emitting units formed between the first and second electrodes,

TABLE 6

	Comparative Example 6	Comparative Example 7		Example 3		Comparative Example 8	
Thickness T1	Ref (<600 Å) + 100 Å						
Second blue dopant	Long wavelength	Long wavelength	Long wavelength	Short wavelength	Short wavelength	Short wavelength	Short wavelength
First blue dopant	Long wavelength	Short wavelength	Short wavelength	Long wavelength	Long wavelength	Short wavelength	Short wavelength
Efficiency of blue light (Cd/A)	4.27	3.63	3.62	3.69	3.89	3.40	3.32
Color coordinates (Y)	0.066	0.061	0.062	0.053	0.057	0.049	0.05
Color gamut (NTSC1976)	98%	100%	99%	104%	102%	105%	102%

[0057] In addition, as shown in Table 6, the organic electroluminescent device of Example 3, in which the first thickness T1 is increased by about 100 Å as compared to organic electroluminescent devices according to Comparative Examples 6 to 8 and the second blue dopant has a shorter wavelength than the first blue dopant, exhibits little reduction

wherein any one of the first and second light emitting units comprises the first blue emission layer, the other of the first and second light emitting units comprises a yellow-green emission layer, and the third light emitting unit comprises the second blue emission layer.

3. The organic electroluminescent device according to claim 2, wherein the maximum luminescence wavelength of the first blue dopant is greater than the maximum luminescence wavelength of the second blue dopant.

4. The organic electroluminescent device according to claim 3, wherein the maximum luminescence wavelength of each of the first and second blue dopants is 430 nm to 480 nm, and the maximum luminescence wavelength of the first blue dopant is greater by 4 nm to 50 nm than the maximum luminescence wavelength of the second blue dopant.

5. The organic electroluminescent device according to claim 3, wherein the maximum luminescence wavelength of the second blue dopant is 430 nm to less than 456 nm, and the maximum luminescence wavelength of the first blue dopant is 456 nm to 480 nm.

6. The organic electroluminescent device according to claim 5, wherein a distance from a rear surface of the first blue emission layer of the first light emitting unit to a rear surface of the yellow-green emission layer of the second light emitting unit is 600 Å to 1000 Å.

7. The organic electroluminescent device according to claim 6, further comprising N-type and P-type charge generation layers respectively formed between the first and second light emitting unit and between the second and third light emitting units,

wherein the N-type charge generation layer disposed between the first blue emission layer of the first light emitting unit and the yellow-green emission layer of the second light emitting unit has a thickness of 50 Å to 500 Å.

8. An organic electroluminescent display device comprising:

first and second electrodes facing each other on a substrate; a plurality of thin film transistors electrically connected to the first electrode; and

at least two emission layers formed between the first and second electrodes and realizing blue light,

wherein, among the emission layers, a first blue emission layer close to the first electrode comprises a first blue dopant having a different maximum luminescence wavelength than that of a second blue dopant of a second blue emission layer close to the second electrode.

* * * * *

专利名称(译)	有机电致发光器件和有机电致发光显示器件		
公开(公告)号	US20150188073A1	公开(公告)日	2015-07-02
申请号	US14/558430	申请日	2014-12-02
[标]申请(专利权)人(译)	乐金显示有限公司		
申请(专利权)人(译)	LG DISPLAY CO. , LTD.		
当前申请(专利权)人(译)	LG DISPLAY CO. , LTD.		
[标]发明人	AHN SO YEON HAN CHANG WOOK CHOI HONG SEOK JOUNG SEUNG RYONG CHO GWI JEONG CHOI HEE DONG		
发明人	AHN, SO-YEON HAN, CHANG-WOOK CHOI, HONG-SEOK JOUNG, SEUNG-RYONG CHO, GWI-JEONG CHOI, HEE-DONG		
IPC分类号	H01L51/50 H01L27/32		
CPC分类号	H01L51/5044 H01L27/3244 H01L27/3209 H01L51/5278 H01L2251/558 H01L51/5012 H01L51/504		
优先权	1020130168049 2013-12-31 KR		
其他公开文献	US9444066		
外部链接	Espacenet USPTO		

摘要(译)

讨论了具有提高的效率的有机电致发光器件和有机电致发光显示器件。在一个示例中，有机电致发光器件包括在基板上彼此面对的第一和第二电极以及在第一和第二电极之间形成并实现蓝光的至少两个发光层，其中，在发光层中，第一蓝色发光层关闭第一电极包括第一蓝色掺杂剂，其具有与靠近第二电极的第二蓝色发射层的第二蓝色掺杂剂不同的最大发光波长。

